

## Alloy Steel Bow Shackle Specifications

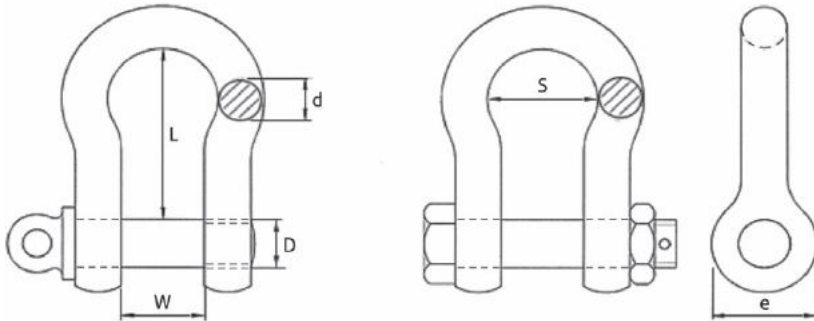

### To US Federal Specification RR-C-271D

With either Screw Collar Pins or Bolt, Nut & Split Pin

SWL te	d	D	w	L	e	s
0.33	5	6	9.5	22	12.5	16
0.5	7	8	12	29	17	20
0.75	9	10	13.5	32	21	22
1	10	11	17	36.5	23	26
1.5	11	13	19	43	26	29
2	13.5	16	22	51	34	32
3.25	16	19	27	64	40	43
4.75	19	22	31	76	47	51
6.5	22	25	36	83	53	58
8.5	25	28	43	95	60	68
9.5	28	32	47	108	67	75
12	32	35	51	115	74	83
13.5	35	38	57	133	80	92
17	38	42	60	146	89	99
25	45	50	74	178	104	126
35	50	57	83	197	119	138
42.5	57	65	95	222	134	160
55	65	70	105	260	145	185

Technical Data

[Marine Catalogue](#)

[Working Load Limits](#)

[Bow Shackle Specifications](#)

[Dee Shackle Specifications](#)

[Videos](#)





## Lifting Gear & Safety

Bristol: 0117 971 4883  
Newport: 01633 334 450

Plymouth: 01752 474 488  
Port Talbot: 01639540007

Fareham: 01329 550 988  
Milford Haven: 01646574 000

Redruth: 01209 703990  
Avonmouth: 01179550456

Dudley:

01384987550

- ▶ Ropes & Rigging (1)